



## THE QUIET ONE®

### The Quietest Commercial Blender Available

The ultimate blender with unparalleled sound reduction, exceptional beverage blends, and improved speed of service.

### Smart Product Design

- Up to 4 times quieter than the competition due to the advanced vibration dampening technology; resulting in quality drinks in a more enjoyable atmosphere
- Magnetically secured floating sound enclosure is dramatically easier to clean and disassemble. No screws to damage the enclosure
- 6 programmes buttons with 34 optimised programme for easier, consistent blending
- Advance® container creates faster, smoother pouring and has a longer blade life resulting in time and cost savings along with improved customer experience
- Air management and powerful  $\approx 3$  peak output HP motor reduces noise, improves reliability and reduces down time



Creamy fruit smoothies

## Product Specifications

### The Quiet One®

Item Number: On-Counter: 50031  
In-Counter: 51024

Motor: ≈3 peak output horsepower motor

Electrical: 220 – 240 V, 50/60 Hz, 1300 – 1500 W

Pack: Includes The Quiet One® with 1.4 L high-impact, clear/stackable Advance® container complete with Advance blade assembly and lid, and removable compact enclosure.

Net Weight: 9.1 kg, (12.7 kg with box)

Dimensions:

On-Counter: 45.7 x 21.6 x 27.2 cm (H x W x D)  
Height with lid open: 62.2 cm

In-Counter: 41.9 x 21.6 x 27.2 cm (H x W x D)  
Height with lid open: 58.4 cm  
Depth below counter: 3.0 cm

Warranty: Please contact your authorised Vitamix distributor for warranty information.

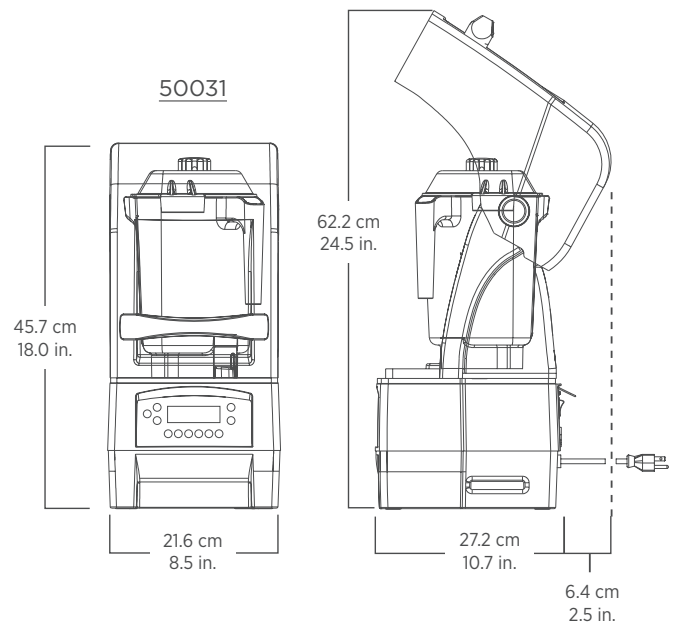

### Also Available

Additional containers, complete with blade assembly and lid.

Item Number: 15978: Advance container 1.4 L

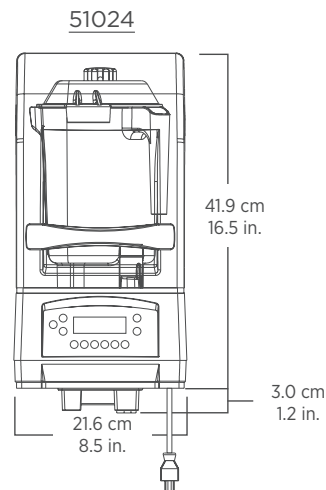

Where applicable:



## Contact Information

U.S.A., Canada & Latin America:

Phone: 800.4DRINK4 or  
800.437.4654

Email: [foodservice@vitamix.com](mailto:foodservice@vitamix.com)

[vitamix.co.uk](http://vitamix.co.uk)

Vita-Mix Corporation  
8615 Usher Road  
Cleveland, OH 44138-2103 U.S.A.

For UK sales or more information, contact your local UK foodservice distributor:

Jestic Foodservice Equipment  
Phone: +44 (0) 8455.048050  
Email: [info@jestic.net](mailto:info@jestic.net)

[www.jestic.co.uk](http://www.jestic.co.uk)