



### *Unmatched Performance in Commercial Kitchens*

Professional chefs and culinary schools around the world trust the Vita-Prep 3 for its exceptional power, versatility, and performance. From chopping delicate ingredients to blending tough purées, the Vita-Prep 3 provides the power and dependability required in the most demanding kitchens.

### *Smart Product Design*

- ≈3 peak output HP motor delivers unmatched performance when puréeing, grinding, chopping and more
- Variable Speed Control and Tamper allow for control and easy processing of dense ingredients
- Sturdy, intuitive controls minimize training time and provide improved grip
- Advanced cooling fan provides optimum reliability during peak hours of operation
- BPA-free, high-impact 2.0-Litre container has a removable lid plug to easily add ingredients while blending

10089 • 58627 • 10090

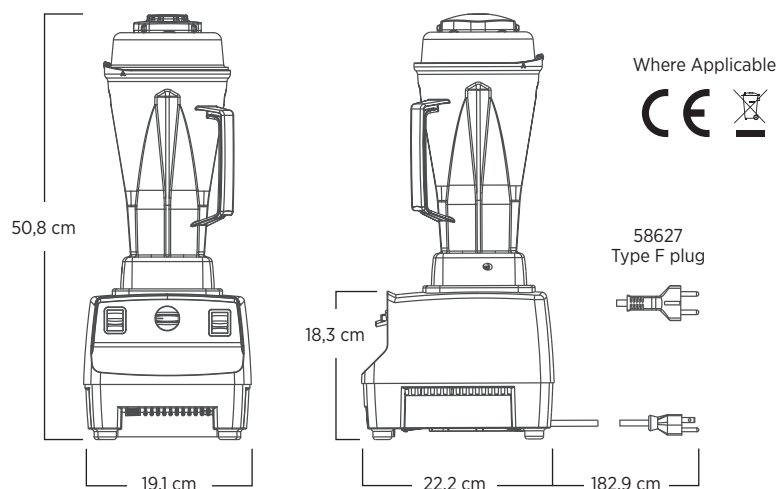

Includes Vita-Prep 3 with 2,0 L high-impact, clear container complete with blade assembly and lid, tamper, and black base.

For more complete warranty terms and conditions, please contact your authorised Vitamix distributor.

### Product Specifications

Item Number	10089	58627 Type F Schuko plug	10090
Motor	≈3 peak output horsepower motor		
Electrical	220-240 V, 50 Hz, 1100-1200 W	220 V, 50 Hz, 1100-1200 W	220-240 V, 60 Hz, 1100-1200 W
Net Weight	5,73 kg, (6,73 kg with box)		
Dimensions	50,8 x 19,1 x 22,2 cm (HxWxD)		

### Also Available

58626	2,0 L BPA-free, clear container complete with Wet blade assembly and lid
-------	--

### Contact Information

+1.440.782.2450

international@vitamix.com



vitamix.com

For more information, please contact an authorised Vitamix distributor, or Vitamix international customer service.